



# PROVEN PERFORMER

## Compact Commercial Laundry

LTEE5A (stack washer/dryer - electric)

LTGE5A (stack washer/dryer - gas)

### Stack washer/dryer features

- Improved suspension with new out-of-balance logic manages and redistributes unbalanced loads for uninterrupted wash cycles
- Water use is trimmed to 45 litres per cycle to reduce operating costs
- Efficient dryer heating with 21 MJ (gas models) and up to 4,000 Watts (electric models)
- Large, easy-to-clean lint compartment
- 1913.8 sq. cm door opening is the largest in the industry, providing easy loading and unloading
- High spin speed up to 1,200 rpm removes more water from clothes, speeding up drying cycles and lowering energy usage
- Moisture sensing system gives accurate temperature control, protecting garments and reducing energy consumption

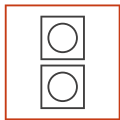

STACK UNIT



STAINLESS STEEL WASHER DRUM



LARGE DOOR OPENING



LOW WATER CONSUMPTION



LOW ENERGY CONSUMPTION



COMPACT DESIGN

### Controls

#### Stack washer/dryer Electronic Control

The Electronic Control keeps users informed throughout the wash process with cycle status lights and a digital cycle countdown. Users also have the flexibility to control temperature, spin speeds, and soil levels, as well as the option of a pre-wash and/or additional rinse to achieve high levels of efficiency. Automatic (moisture sensing) cycles come standard.



LTEE5A, LTGE5A

	LTEE5A (Electric)		LTGE5A (Gas)	
	Stack Washer	Stack Dryer	Stack Washer	Stack Dryer
Type	Stack Washer	Stack Dryer	Stack Washer	Stack Dryer
Control	Electronic	Electronic	Electronic	Electronic
Control location	Front	Front	Front	Front
<b>Drum</b>				
Capacity kg	10 kg	10 kg	10 kg	10 kg
Cylinder volume litres	96.8 Lt	198 Lt	96.8 Lt	198 Lt
<b>Drum speed</b>				
Spin speed G-Force	440	n/a	440	n/a
Spin speed rpm	1200	n/a	1200	n/a
<b>Motor</b>				
Motor size kW	Variable speed induction 0.67	0.25	Variable speed induction 0.67	0.25
<b>Cabinet</b>				
Cylinder finish	Stainless steel	Stainless steel	Stainless steel	Stainless steel
Colours	White	White	White	White
Door type (solid/window)	Window	Window	Window	Window
<b>Heating</b>				
Heat sources	n/a	Electric	n/a	Gas
Heating element (Electric W)	n/a	4000	n/a	n/a
<b>Connection</b>				
Gas inlet connection mm	n/a	n/a	n/a	9.5
Gas consumption MJ/Hr	n/a	n/a	n/a	21.09 MJ
Exhaust outlet dia. mm	n/a	102	n/a	102
Exhaust airflow litres/sec	n/a	85	n/a	85
Water temperatures	3	n/a	3	n/a
<b>Operation</b>				
Cycles	Heavy Duty, Normal Eco, Perm Press, Delicate, Rinse and Spin, Spin Only	Dryer: Regular, Perm Press, Delicate, Time Dry, Quick Dry, Fluff Up	Heavy Duty, Normal Eco, Perm Press, Delicate, Rinse and Spin, Spin Only	Dryer: Regular, Perm Press, Delicate, Time Dry, Quick Dry, Fluff Up
Water consumption per cycle litres	44.3	n/a	44.3	n/a
Water pressure kPa	140/830 kPa	n/a	140/830 kPa	n/a
Cycle indicator lights	Digital display	Digital display	Digital display	Digital display
<b>Power</b>				
Electrical requirements (voltage/Hz/Ph)	240/50/1, 6 amp	240/50/1, 20 amp	240/50/1, 6 amp	240/50/1 4 amp
<b>Transport data</b>				
Net weight kg	177 (combined)		177 (combined)	
Shipping weight kg	193 (combined)		193 (combined)	
Dimensions H×W×D mm	1986×683×704		1986×683×704	
Packing dimensions H×W×D mm	2032×737×832		2032×737×832	
<b>Agency approvals</b>				
Available agency approvals	Electric SAA		Electric SAA, Gas AGA #4946	



## Dimensions

### Stack Washer/Dryer – electric

	A	B	C	D	E	F	G	H	I	J	K	L	M	N	O	P	Q
<b>LTEE5A</b>	1678*	1447*	597	213	610	203	391	938*	368*	813*	683	1184*	1986*	52	704	38	333*

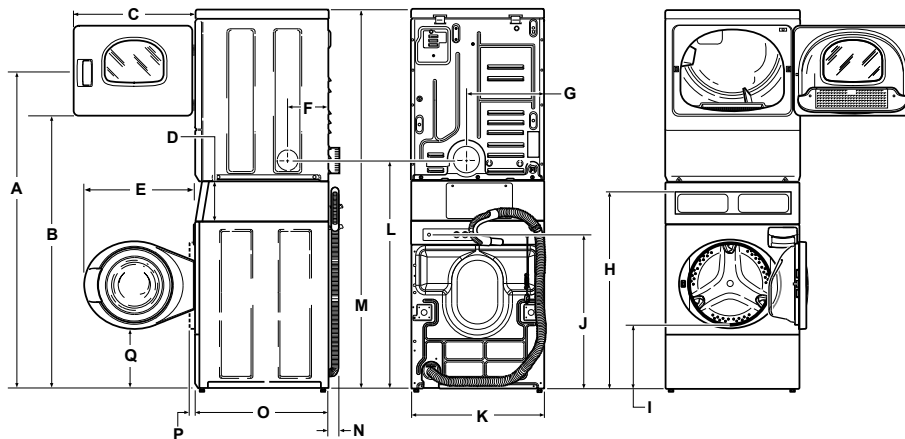

### Stack Washer/Dryer – gas

	A	B	C	D	E	F	G	H	I	J	K	L	M	N	O	P	Q	R
<b>LTGE5A</b>	1678*	1447*	597	213	610	203	391	59	938*	368*	1140*	813*	683	1184*	1986*	52	704	38

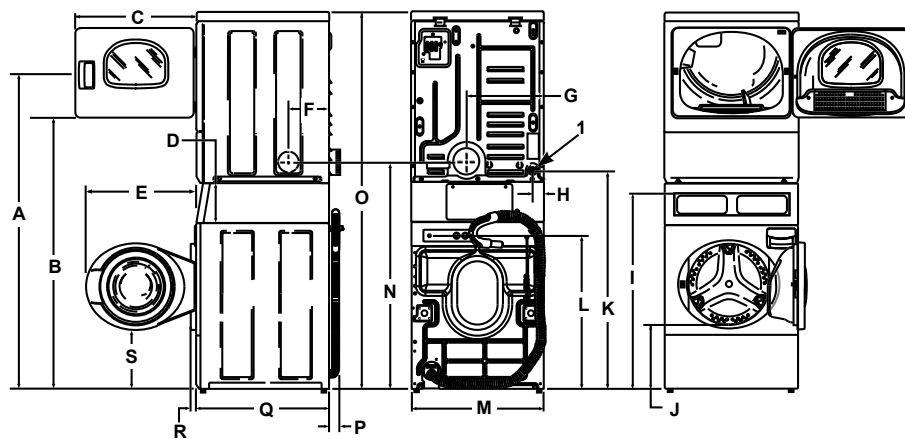

1 = 10mm NPT Gas Connection

All measurements are in mm. \*With levelling legs turned into base.

NOTE: Exhaust openings are 102 mm metal ducting.





Speed Queen Equipment Sales Pty. Ltd.  
26 Theobald Street, Thornbury, Vic 3071  
Ph: (03) 9495 1300  
Fax: (03) 9495 1600  
W: [www.speedqueensales.com.au](http://www.speedqueensales.com.au)  
E: [sales@speedqueensales.com.au](mailto:sales@speedqueensales.com.au)  
Servicing Victoria, Tasmania, S.A. & N.T.